

Load-sensitive bus headway control for reducing onboard passenger waiting time

Redução da espera a bordo por controle de intervalo entre ônibus adaptado ao carregamento

Lucas Franco Lima¹, Rodrigo Castelan Carlson², Werner Kraus Junior³, Lucas Zimmermann⁴, Luiz Alberto Koehler⁵

¹Federal University of Santa Catarina, Santa Catarina – Brazil, lucasfranco@ufsc.br

²Federal University of Santa Catarina, Santa Catarina – Brazil, rodrigo.carlson@ufsc.br

³Federal University of Santa Catarina, Santa Catarina – Brazil, werner.kraus@ufsc.br

⁴Federal University of Santa Catarina, Santa Catarina – Brazil, zim.lucas@gmail.com

⁵Regional University of Blumenau, Santa Catarina – Brazil, luiz@furb.br

Recebido:

30 de junho de 2021

Aceito para publicação:

18 de outubro de 2021

Publicado:

31 de dezembro de 2021

Editor de área:

Cira Pitombo

Keywords:

Bus headway control.

Variable gain.

Public transport.

Palavras-chave:

Controle de intervalo entre ônibus.

Ganho variável.

Transporte público.

DOI:10.14295/transportes.v29i3.2650

ABSTRACT

Regularity in the bus schedule on low frequency lines or the maintenance of headways on high frequency lines are desired in the operation of public transportation. Bus holding is a technique used for this purpose, but it may incur in delays for onboard passengers. Previous work based on a predictive control method identified a better performance when the holding actions were concentrated in stations where the buses were emptier. Based on these results, the forward headway and the two-way headway feedback control methods, both operated with static gains and mathematically and computationally simpler than predictive control, are modified to operate with variable gains according to the bus load using two different techniques. A variable slack, dependent on the bus load, is also incorporated into the controllers. Microsimulations of a BRT corridor with concentrated and distributed demand patterns have shown that the proposed techniques improve the system performance when compared to the corresponding methods with fixed gain.

RESUMO

A regularidade no cronograma de ônibus em linhas de baixa frequência ou a manutenção de intervalos nas de alta frequência são desejadas na operação do transporte coletivo. A retenção é uma técnica usada para estes fins, porém pode incorrer em atraso para os usuários embarcados. Trabalho anterior baseado em um método de controle preditivo identificou melhor desempenho quando as retenções foram concentradas em estações nas quais os ônibus estavam mais vazios. Com base nesses resultados, os métodos de controle realimentado com intervalo à frente e intervalo à frente e atrás, ambos operados com ganhos estáticos e matemática e computacionalmente mais simples do que o controle preditivo, são modificados para operarem com ganhos variáveis de acordo com o carregamento usando duas técnicas diferentes. Um tempo de regulação variável com o carregamento também é incorporado aos controladores. Microsimulações de um corredor BRT com padrões de demanda concentrada e distribuída mostram melhor desempenho do sistema com as técnicas propostas em relação ao uso de ganho fixo.



1. INTRODUCTION

In public transport services, there is a considerable difficulty in complying with the stipulated schedules or maintaining headways between buses. This is due to variations in the speed of the vehicles, traffic lights and in the passengers' dwell times, among other factors.

The consequence is a tendency of bus bunching when no control tools are applied to prevent this behavior. Therefore, an irregularity in bus schedules and intervals results. Indeed, a bus that is delayed ends up finding more passengers ahead, which increases boarding times and its delay; meanwhile, an early bus serves fewer passengers and gets ahead even more (Newell and Potts, 1964).

The bus bunching phenomenon occurs even in systems that have exclusive corridors and pre-boarding platforms for their operation, such as the Bus Rapid Transit (BRT) (Zimmermann, 2015). Even with pre-boarding supporting equipment, which render boarding and alighting times more predictable, buses remain subject to different driving speeds and traffic lights. Besides, due to the high frequency operation, any disturbance is worsened (Wright and Hook, 2007).

One of the ways to reduce operational instability in public transport systems is the holding of buses that are ahead of schedule or have too short headways in their route (Ibarra-Rojas *et al.*, 2015). The goal is to improve compliance with a timetable on low-frequency lines or to increase headway regularity on high-frequency lines (Barnett, 1974). To this end, real-time control methods can be used along with information from the system in operation (Eberlein *et al.*, 2001).

The application of holding by real-time control methods increases the reliability of the system, reduces the average waiting time of passengers at stations, and results in a more balanced distribution of passenger load between buses. It implies, however, a longer waiting time experienced by passengers already boarded (Zimmermann *et al.*, 2015).

Zimmermann (2016) compared, via traffic microsimulation, a few feedback control methods with a model-based predictive control method for a BRT corridor proposed by Koehler *et al.* (2011). The feedback methods control the intervals between buses in order to maintain regularity. The predictive method defines holding values in order to minimize an objective function that represents the waiting time of both users at the stations and passengers already on board (Koehler *et al.*, 2011). Different demand patterns were simulated along with each of the control methods. In the results of Zimmermann (2016), it was observed that the users of the system benefit more from the control action when holding at stations is applied for buses with low loads, allowing a greater variation of headways when the bus load is higher. Part of the difference in performance between feedback and predictive methods in this case stems from the fact that only predictive control considers the load of buses for the calculation of holding times.

The best waiting times for users of the system obtained with the predictive control method depend, however, on a significantly greater amount of information. In addition, greater calculation times are necessary due to the computational complexity of its implementation. Thus, it seems promising to use a simple feedback control method adjusted through observations of how predictive control works, with focus on situations in which the bus load is highly irregular along the itinerary.

In order to replicate the performance of the predictive control method of Zimmermann *et al.* (2016), Lima *et al.* (2019) proposed the use of a feedback controller in which the gain varies with the load instead of using a fixed or nominal gain. The proposed method, mathematically and computationally simpler than predictive control, applied longer holding times at stations where the buses were less loaded, as desired. However, in segments without load variation, the gain saturated at too high or too low values, impairing its performance.

The objective of the present work is improving the control methods with variable gain. This is done in two ways. First, the regulation time technique previously proposed by Daganzo (2010), and widely used in practice by operators, is incorporated into the feedback control methods. However, instead of a fixed regulation time, a variable time is proposed according to historical records of the bus load of the line. In addition, two new gain variation techniques that avoid its saturation are proposed. The first technique consists of analyzing the bus load historical data of the line in operation already in the planning stage. These data are then used to define gain values for each station. The second technique also makes use of historical data, but for the configuration of internal gains of a second controller that defines, based on real-time bus load data, a variable multiplication factor of the nominal gain. The new methods were tested in microsimulation for a 31 km-long bus line with 30 stations on a projected BRT system.

In Section 2, existing bus holding control methods are presented. In Section 3, the incorporation of the variable regulation time and the new gain variation techniques are presented. In Section 4, the performance indicators used for the evaluation are presented, as well as the simulation scenario. The results are presented and discussed in Section 5. Finally, Section 6 concludes the work.

2. HEADWAY CONTROL METHODS

Three control methods were chosen for comparison with the proposed techniques: regulation in the origin terminal (ROT); forward headway control (FH); and two-way headway control (TWH). The last two, normally operated with fixed gains, are also applied with the proposed variable gain techniques in this work.

2.1. Regulation in the origin terminal (ROT)

The regulation in the origin terminal uses the standard deviation of travel times between stations to define a regulation time, or slack (S_{tot}). This slack is then added to the cycle time (T_c), that is, to the time expected between two departures of the same bus from the origin terminal. This technique is used to ensure that delayed buses are available for the start of a new trip, according to the stipulated headway or schedule.

The total regulation time can be given as (Daganzo, 2010):

$$S_{tot} = N_K 2\sigma_{avgv} \quad (1)$$

with N_K the number of stations in the line and σ_{avgv} the average standard deviation of travel times. The new cycle time can then be calculated as:

$$T_c = \sum_{k=0}^{N_K} v_{avgk} + S_{tot} \quad (2)$$

with v_{avgk} the average travel time between stations k and $k + 1$. In addition, a new planned headway for high frequency lines must be defined:

$$H = \frac{T_c}{N_I} \quad (3)$$

with N_I the total number of buses in operation in the line. Therefore, the buses depart from the origin terminal with a time difference corresponding to the new planned interval (H) and follow the itinerary subject to the various disturbances of the system.

During their journeys, the vehicles do not perform any control action; that is, the holding is zero for all buses i at all stations k except at the origin terminal ($k = 0$). In this case, the holding for all buses is given by:

$$r_{i,0} = \left[T_c - \sum_{k=0}^{N_K} (v_{i,k} + w_{i,k}) \right]^+ \quad (4)$$

with $v_{i,k}$ the travel time of bus i between stations k and $k + 1$, and $w_{i,k}$ the dwell time for passengers from bus i at station k during its most recent completed trip turn on the itinerary and $[u]^+ = \max\{0, u\}$.

Thus, whenever a bus completes the alighting process at the origin station, the current cycle time is compared with the planned one. If the current cycle time is shorter, the necessary holding is applied so as to establish the planned cycle time. The maximum holding time to be applied is the total regulation time S_{tot} .

2.2. Forward headway control (FH)

The forward headway control (FH) (Cats *et al.*, 2011) computes holding times when a bus operates with an interval from the bus ahead that is lower than the planned headway, immediately correcting this deviation. The holding applied by bus i at station k is given by:

$$r_{i,k} = [s_k + K_N(H - \hat{h}_{i,k})]^+ \quad (5)$$

with K_N the fixed proportional gain that must be adjusted by the operator, $\hat{h}_{i,k}$ the headway from bus i to bus $i - 1$ ahead, and s_k the regulation time at station k , obtained by:

$$s_k = \frac{S_{\text{tot}}}{N_K}. \quad (6)$$

Holding, if necessary, is applied when the process of boarding and alighting of a bus at a station is completed. The FH has the disadvantage of delaying all buses in the system that come behind a slower vehicle, as it determines the application of holding to all of them regardless of the magnitude of their delay. In addition, the bus in front of the slow bus is moving further and further away, since the headway to the vehicle behind is not relevant for the holding calculation. This escape effect is attenuated by the application of the regulation time along the itinerary that allows delayed buses with $\hat{h}_{i,k} > H$ to apply a holding value lower than s_k (see Equation 5).

2.2. Two-way headway control (TWH)

The two-way headway control (TWH) (Turnquist, 1982) seeks balancing the headways between the bus ahead and the bus behind for each vehicle instead of comparing the current and planned headways. The holding applied by the bus i at the station k is given by:

$$r_{i,k} = \left[s_k + \frac{K_N}{2} (h_{i+1,k'} - \hat{h}_{i,k}) \right]^+, \quad (7)$$

where k' represents the last station visited by the bus $i + 1$ behind. Therefore, $h_{i+1,k'}$ refers to the last observed headway between buses $i + 1$ and i .

Since the control action occurs in chain, TWH tends to find a natural headway for the system for all buses. This search for balance between two consecutive headways makes it an efficient method in preventing possible bus escapes.

3. HEADWAY CONTROL WITH VARIABLE GAIN

In this section we propose a distribution of the regulation time along the itinerary that takes into account the historical records of the line's bus load. In addition, two ways of varying the nominal gain K_N are proposed in such a way that the holding times computed by the feedback control methods are longer when the bus load is low. The first form of variation is based only

on the historical data from the bus load of buses on the itinerary, while the second also uses both historical data and real-time information when calculating holding times. Finally, a preliminary analysis of the behavior of the methods is presented.

3.1. Variable regulation time

The use of historical bus load data for buses on a given transit line assumes that these data are already available in the planning stage. In fact, it is common for bus load data to be collected frequently, especially in the sections of critical loading (Ceder, 2007). It is reasonable, therefore, to assume the availability of bus load data for the implementation of headway controllers.

We propose that the total regulation time (S_{tot}) be distributed over the stations of the itinerary according to the loading history of the vehicles of the line rather than uniformly as in Equation 6. Thus:

$$s_{V_k} = \begin{cases} \left(\frac{S_{\text{tot}}}{N_K}\right), & l_{\text{max}} = l_{\text{avg}k} \\ \left(\frac{l_{\text{max}} - l_{\text{avg}k}}{\sum_{k \in K} (l_{\text{max}} - l_{\text{avg}k})}\right) S_{\text{tot}}, & l_{\text{max}} \neq l_{\text{avg}k}, \end{cases} \quad (8)$$

with l_{max} the critical or maximum load of the line and $l_{\text{avg}k}$ the average number of passengers on board at station k . These data come from the itinerary historical data and s_{V_k} is used in place of s_k in the proposed variable gain equations introduced next.

3.2. Variable gain based on historic data ($K_{\text{H}k}$)

The first proposed form of variable gain uses only data from the historical bus load on a line. Similar to what is done for the variable regulation time (Equation 8), this technique redistributes the nominal gain (K_N) defined by the operator in each station k along the itinerary in order to keep it as the average gain of the entire route:

$$K_{\text{H}k} = \begin{cases} K_N, & l_{\text{max}} = l_{\text{avg}k} \\ \left(\frac{l_{\text{max}} - l_{\text{avg}k}}{\sum_{k \in K} (l_{\text{max}} - l_{\text{avg}k})}\right) N_K(K_N), & l_{\text{max}} \neq l_{\text{avg}k}. \end{cases} \quad (9)$$

The proposed gain $K_{\text{H}k}$ follows the opposite behavior to that of the average load curve of the buses.

The holding calculation equations for FH and TWH with variable gain, where the new $K_{\text{H}k}$ replaces the original K_N and s_{V_k} replaces s_k , are changed, respectively, to:

$$r_{i,k} = [s_{V_k} + K_{\text{H}k}(H - \hat{h}_{i,k})]^+ \quad \text{and} \quad (10)$$

$$r_{i,k} = [s_{V_k} + \frac{K_{\text{H}k}}{2}(h_{i+1,k'} - \hat{h}_{i,k})]^+. \quad (11)$$

This proposal, despite being simpler and more intuitive, does not act on possible unexpected variations caused by external factors in the bus load on a line.

3.3. Adaptive real-time gain ($K_{\text{R}i,k}$)

It is desirable to obtain a gain variation scheme with the following characteristics necessary for an adaptive gain adjustment law according to bus load:

1. The gain $K_{\text{R}i,k}$ of bus i at station k should vary proportionally and in reverse to the bus loading:

$$\Delta K_{\text{R}i,k} \propto l_{i,k-1} - l_{i,k}. \quad (12)$$

That is, if the load at the current station ($l_{i,k}$) is greater than at the previous station ($l_{i,k-1}$), the gain should have a negative variation, and vice versa.

2. The variation should be incremental, avoiding leaps. Therefore, it should be possible to adjust the magnitude of the bus load variations, for example, using the gain factor K_V :

$$K_{Ri,k} = K_{Ri,k-1} + K_V(l_{i,k-1} - l_{i,k}). \quad (13)$$

3. If there is no variation in the bus load over several stations, the gain should be gradually restored to a nominal value, preventing it from becoming stagnant at too high or too low values for long stretches with roughly constant bus load:

$$K_{Ri,k} = K_P(K_N - K_{Ri,k-1}). \quad (14)$$

The sum of the three desirable characteristics of the gain variation can be represented by the block diagram of Figure 1. In the diagram, the block z^{-1} corresponds to a sample delay. The adaptive control law for the variable gain shown in the diagram reads:

$$K_{Ri,k} = K_{Ri,k-1} + K_V(l_{i,k-1} - l_{i,k}) + K_P(K_N - K_{Ri,k-1}). \quad (15)$$

The gains K_V and K_P are adjusted empirically based on historical data. The adjustment is made by trial and error in order to influence the gain variation curve to follow the opposite of the loading curve.

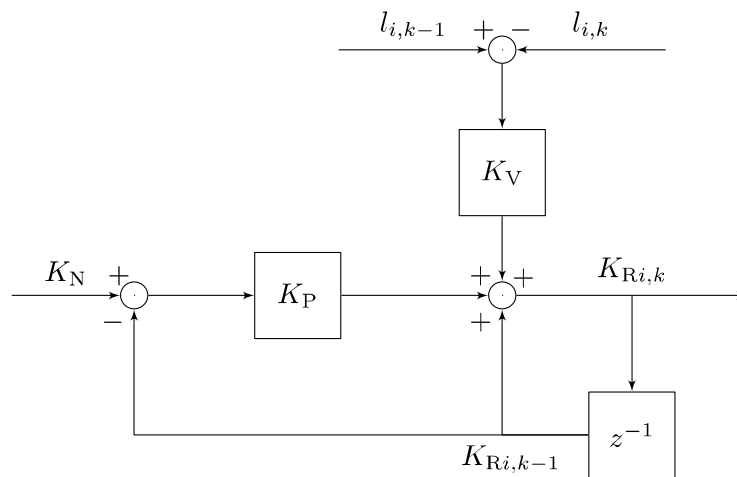

Figure 1. Block diagram representing the structure of the adaptive gain based on the real-time variation of the bus load; the block z^{-1} corresponds to the sample delay

The holding calculation equations for FH and TWH with variable gain, where $K_{Ri,k}$ replaces the original K_N and s_{V_k} replaces s_k , are changed, respectively, to:

$$r_{i,k} = [s_{V_k} + K_{Ri,k}(H - \hat{h}_{i,k})]^+ \quad \text{and} \quad (16)$$

$$r_{i,k} = [s_{V_k} + \frac{K_{Ri,k}}{2}(h_{i+1,k'} - \hat{h}_{i,k})]^+. \quad (17)$$

This proposal has the advantage over the previous one of responding in real time to possible unexpected variations caused by external factors in the bus load of a line.

3.4. Preliminary analysis of the proposed methods

Figure 2 shows the variation of the gains for the two methods proposed in this section over the itinerary for a scenario with concentrated demand. The value of K_{Hk} is the same for all buses on all circuits for each station. The value of $K_{Ri,k}$ varies according to the number of passengers on the bus at the time of holding calculation, so the value shown in the graph is the average of the gain at each station.

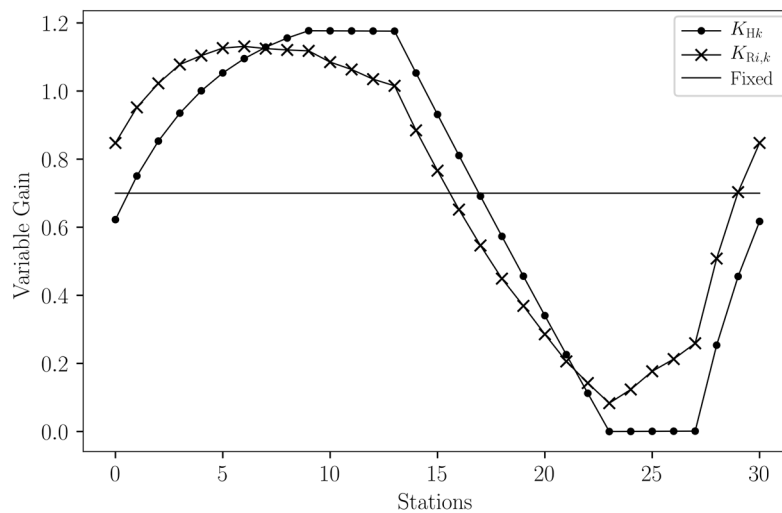

Figure 2. Variation of the proposed gains along the itinerary

In the case of a uniform or a distributed demand scenario, for which the number of passengers in the bus does not vary so much during the itinerary, the variation of the gain is smaller and their behavior is closer to those of the existing methods with which they would be associated.

The sensitivity of the methods to discrepancies in bus load was tested with two different demand patterns, in combination with FH. It was assumed that the real load was different from the historical load used to feed the calculation of the proposed methods. For the variable gain based only on historical data, the test showed that when the real load differs from the historical load with an average of 24% over the route, the average error between the real gain and the ideal gain if the data were correct is 18%.

Since the adaptive gain method uses bus load information in real time, the influence of the error of the same information coming from the history only affects the calibration step of the controller's internal gains. Thus, the comparison was made with the variation of the optimal gains found for each of the bus load profiles. The same deviation of 24% in the historical bus load led to an error in the gain curve of 25%, due to the difference in the internal gains of the controller.

4. PERFORMANCE INDICATORS AND SIMULATION SCENARIO

This section presents the performance indicators used to evaluate the proposed techniques and the simulation scenario along with the two demand patterns used. The simulations were carried out with the traffic microsimulator Aimsun Next 8.4 (AIMSUN, 2020).

4.1. Performance indicators

The performance indicators used to compare the control methods proposed in this work are presented in this section.

4.1.1. Average headway

The arithmetic mean between all the observed headways is the average headway indicator (h_{avg}). Its coefficient of variation (h_{var}) is given by the ratio between the headway standard deviation and average. h_{var} is an important factor to be observed, since the feedback methods

seek exactly to improve this index. On the other hand, a high h_{var} affects the reliability of the system and is easily perceived by the users. The variation in gains of the proposed methods in this work aims at finding a greater “slack” to the headway variation when the buses are more crowded and at applying greater holding times when buses are emptier. Thus, it is expected that the coefficient of variation will be greater, when compared to the feedback methods with fixed gain.

4.1.2. Total holding time applied

The total holding time applied (r_{tot}) for each method represents their control effort and quantifies the delay added to the operation. The higher the total holding time needed to keep the headways regularized, the more the operational speed is impaired, while the case with less control will have the highest operational speed (Eberlein *et al.*, 2001). As a performance indicator, it allows to observe if the proposed control systems deliver an improvement in other indicators without significant changes in r_{tot} .

4.1.3. User waiting times at the stations

A user’s waiting time at a station (E_{sta}) is given by the time interval from the user’s arrival at the station until the moment the boarding and alighting operations of a bus are finished.

4.1.4. User waiting times on board

The waiting time for passengers on board (E_{onb}) accounts for two time intervals: i) the time between the arrival and departure of a bus at a station for users who left the previous station and did not alight at the current station; and ii) the time between the arrival of passengers boarding in the current station and their departure in the bus.

4.2. Simulation scenario

The used scenario models a 39 km line with 30 stations based on a proposed BRT system for the metropolitan area of Florianópolis/SC (PLAMUS, 2015) and employed by Zimmermann (2016). The buses run on exclusive lanes without interaction with mixed traffic and are assumed to have full traffic light priority. Thus, stops on the itinerary occur only at the stations for boarding and alighting of passengers. Overtaking is not allowed, but each station has room for two buses. Since the buses run in circuit, after arriving at the last station and making their stop, they leave again for the first station.

Bus characteristics are defined in terms of acceleration, deceleration and speed acceptance, with mean (standard deviation) set to 1.0 (0.3) m/s^2 , 2.0 (0.3) m/s^2 and 1.0 (0.05), respectively. These values are default for buses in Aimsun Next. Passenger characteristics are defined in terms of arrival rate and alighting fraction at each station and were set according to the demand patterns described next.

4.2.1. Concentrated demand

A concentrated demand pattern was used to assess the performance of controllers with variable gain in this type of scenario, in which the predictive control method stands out in relation to proportional feedback controllers (Zimmermann, 2016). Thus, a section is considered with a strong travel origin characteristic in which many users board and no users alight, and a second section with strong destination characteristics in which there are only with users alighting (Figure 3).

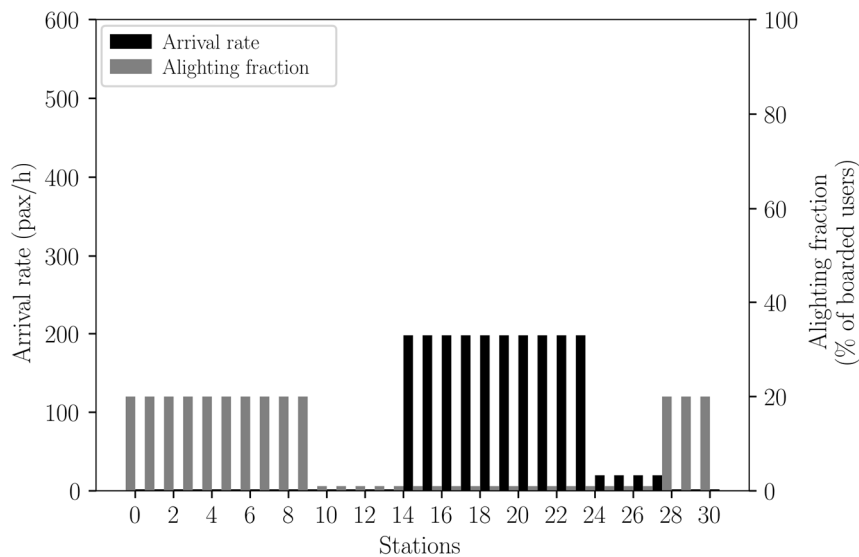

Figure 3. Pattern of concentrated user demand for testing the control methods

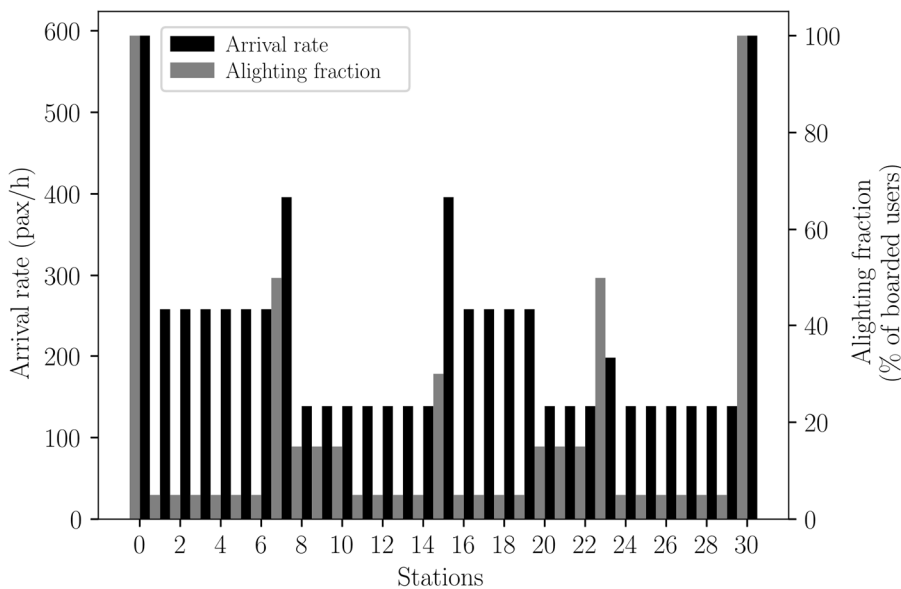

Figure 4. Pattern of distributed user demand for testing the control methods

4.2.2. Distributed demand

The simulation scenario previously described was also used in combination with a distributed demand pattern estimated according to empirical knowledge from the area in which the BRT corridor would be implemented (Figure 4). The proposed techniques were tested along with the FH method. It is expected that, with less variation in loading on buses along the itinerary, there should also be a decrease in the variation of gains of the proposed methods. Their behaviors should approximate that of existing fixed gain methods. More details from the simulated scenario implemented in Aimsun can be seen in Lima (2020).

5. RESULTS ANALYSIS

The results presented in this section are compiled from average values of ten replications simulating one hour of operation each. In each replication, around 4100 users were transported

in the scenario of concentrated demand and around 12000 users for the distributed demand. In both cases sixteen buses were in operation. The methods that are combined with the variable gain technique based only on historical data are identified by the suffix “vh”, while the methods that use real-time information are identified by the suffix “vr”.

5.1. Concentrated demand

The control methods with fixed gain were applied with nominal gain $K_N = 0.7$. The internal gains of the “vr” methods for the concentrated demand pattern were $K_P = 0.05$ and $K_V = 0.011$ adjusted empirically, as described in Section 3.3. The planned headway was $H = 195$ s and the total regulation time was $S_{tot} = 240$ s. The results of the control application are shown in Table 1.

Table 1 – Performance of the tested methods for the concentrated demand pattern

Methods	h_{avg} (s)	h_{var}	r_{tot} (s)	E_{sta} (s)	E_{onb} (s)
ROT	192	0.45	7456	128	178
FH	195	0.01	9392	97	182
FHvh	195	0.06	9226	98	146
FHvr	195	0.07	9519	97	164
TWH	194	0.04	8966	97	177
TWHvh	194	0.09	8988	98	135
TWHvr	196	0.10	9825	99	150

5.1.1. Evaluation of average headway and coefficient of variation for concentrated demand

While the average headway remained similar for all methods, the coefficient of variation (h_{var}) was lower for cases that apply holding throughout the route than for the ROT in the concentrated demand pattern scenario (Table 1). As expected, methods with fixed gain, which seek greater regularity, presented the lowest values in this indicator.

Figure 5 shows the headway coefficient of variation along the route for the forward headway control methods with concentrated demand. The existing method (FH) kept the headways more regular throughout the route. The proposed methods (FHvh and FHvr) allowed for a greater variation in the headways at stations where buses have more onboard passengers and sought greater regularization at stations with empty buses (see loading example in Figure 6).

5.1.2. Evaluation of total holding time applied for concentrated demand

The feedback methods with control throughout the itinerary always apply more holding (r_{tot}) than the ROT (Table 1). In Figure 6, the average load of the buses was calculated using the arithmetic mean between the different applied methods. In addition, values related to the control effort of the three methods tested with TWH are presented. There is a great difference in the profile of control effort between the methods that take into account the number of onboard passengers in the buses. Both “vh” and “vr” methods concentrate the application of holding in stations where buses are emptier, while fixed gain methods distribute the holding applied along the itinerary. The ROT does not appear in this graph since all the holding time applied by this method is concentrated in station 0.

5.1.3. Evaluation of waiting times for users at the stations and on board for concentrated demand

All methods with holding application throughout the itinerary were able to improve around

24% the waiting time of users at the station (E_{sta}) compared to the ROT method. Both “vh” and “vr” achieved a considerable decrease in the waiting times for onboard passengers (E_{onb}) when compared to the fixed gain methods (Table 1). The improvement in the waiting times for the users was achieved without significant cost from the headway coefficient of variation (h_{var}). The increase in total holding (r_{tot}) for methods was higher for the “vr” than for “vh” method, but they are still compensated by lower waiting times for boarded passengers.

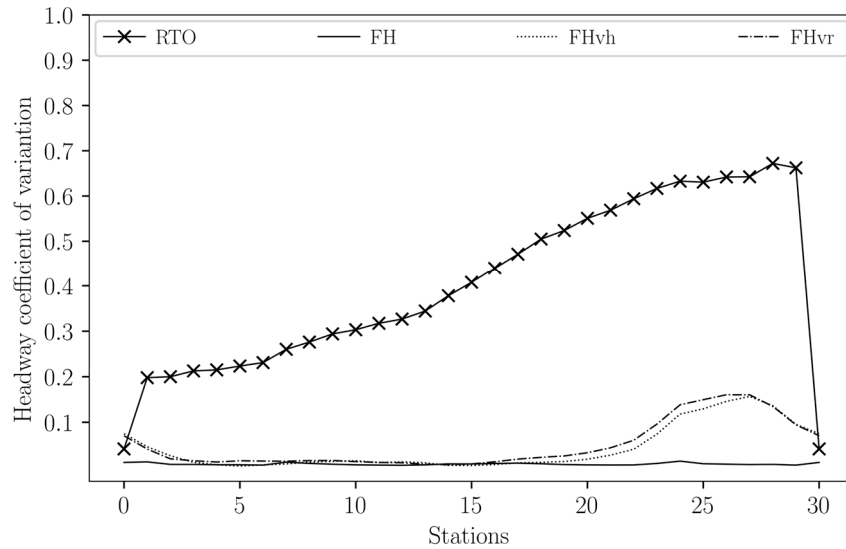

Figure 5. Coefficient of variation of headways along the route for different control methods in concentrated demand pattern scenario

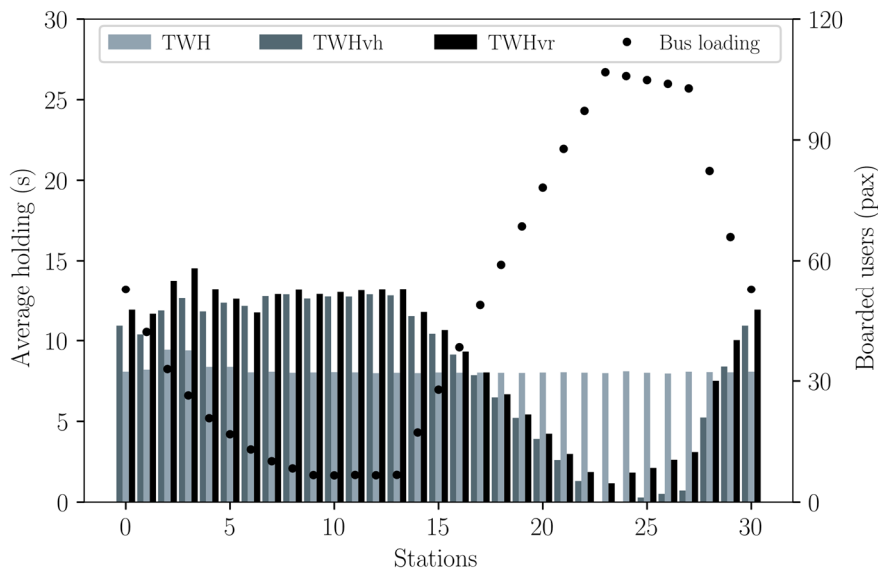

Figure 6. Control action of the tested methods and average loading along the itinerary

5.2. Distributed demand

With the distributed demand pattern, the internal gains for the “vr” methods had to be readjusted and were set to $K_p = 0.1$ and $K_v = 0.018$. Since there are more passengers in the system, the dwell times end up increasing and that leads to higher headways. The new planned headway was $H = 209$ s and the total regulation time was $S_{tot} = 300$ s. The results of the control application are shown in Table 2.

Table 2 – Performance of the tested methods for distributed demand pattern

Methods	h_{avg} (s)	h_{var}	r_{tot} (s)	E_{sta} (s)	E_{onb} (s)
ROT	204	0.56	7078	140	68
FH	209	0.01	9515	105	114
FHvh	209	0.03	9573	105	106
FHvr	211	0.05	10144	106	110
TWH	210	0.04	9919	105	117
TWHvh	209	0.05	9364	105	106
TWHvr	210	0.05	9839	105	109

5.2.1. Evaluation of average headway and coefficient of variation for distributed demand

In the distributed demand scenario, it can also be seen that the methods that apply holding along all the stations obtain smaller values for headway variation (Table 2). The behaviour of the proposed methods is closer to the existing ones with fixed gain when compared to the concentrated demand scenario due to more distributed bus loading along the itinerary (see loading example in Figure 8), as expected. The headway variation along the route with distributed demand can be seen in Figure 7.

5.2.2. Evaluation of total holding time applied for distributed demand

It is possible to confirm, with the distributed demand scenario, that the feedback methods with control throughout the itinerary apply larger total holding times (r_{tot}) than the ROT (Table 2). In Figure 8, it can be seen the average load of the buses along the route for the distributed demand pattern. It is possible to notice that the distribution of holding by the proposed methods is different from that of the fixed gain FH, that applies its control effort evenly among all stations. Even so, that difference is lower when compared to the results from the concentrated demand pattern, as the variation in bus load in that scenario is greater.

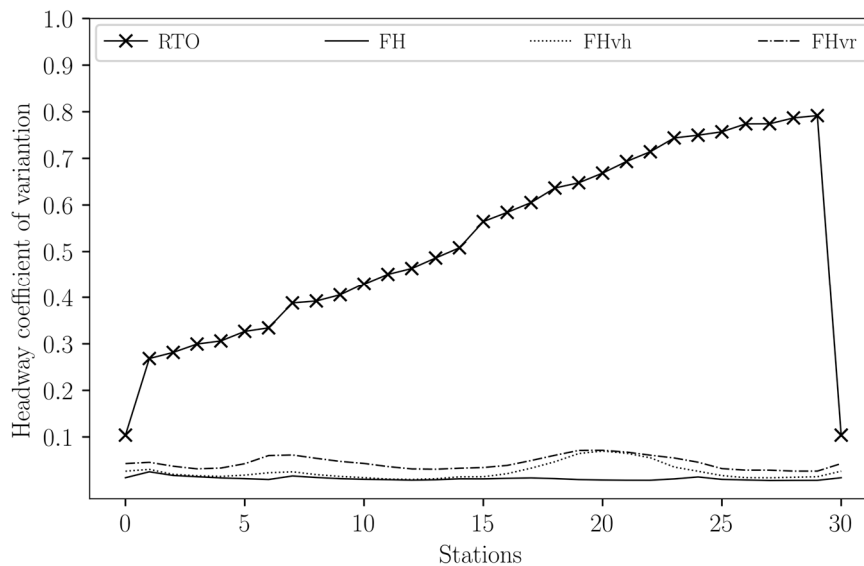

Figure 7. Coefficient of variation of headways along the route for different control methods in distributed demand pattern scenario

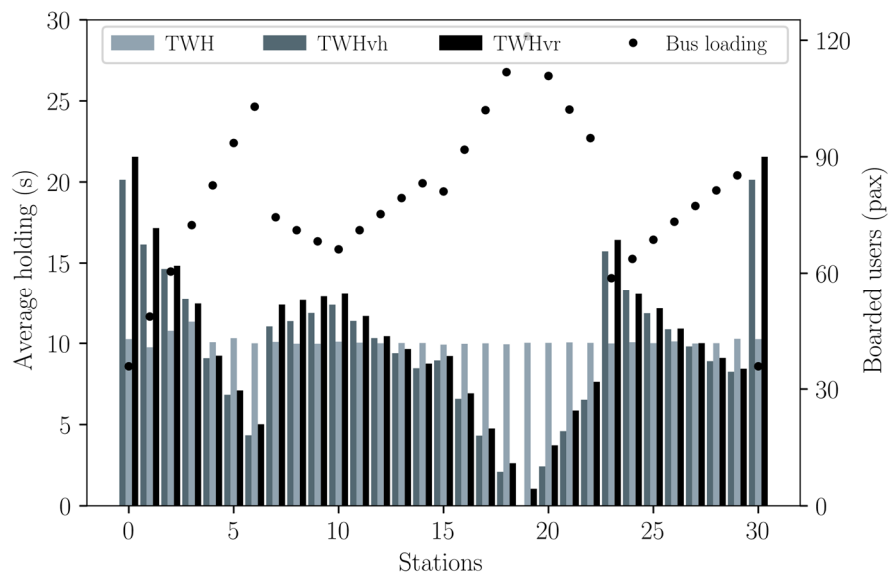

Figure 8. Control action of the tested methods and average loading along the itinerary with distributed demand.

5.2.3. Evaluation of waiting times for users at the stations and on board for distributed demand

In the distributed demand scenario, the methods with holding application throughout the itinerary were still able to improve around 25% the waiting time of users at the station (E_{sta}) compared to the ROT method (Table 2). On the other hand, the proposed techniques were not capable of significantly improving the waiting times for onboard passengers (E_{onb}) and have their results closer to those of the fixed gain methods.

6. CONCLUSION

It has been proposed the inclusion of a variable regulation time and two new gain variation techniques for use in feedback control by public transport holding. These techniques were employed with two existing feedback control laws: forward headway control (FH) and two-way headway control (TWH), maintaining their main characteristics, but operating with regulation time and variable, rather than fixed, gains. Variations in these parameters were made according to the load of each bus at each station.

The development of these techniques was based on Zimmermann (2016) who concluded that in scenarios where demand provides a constant load of buses along the itinerary, greater regularization of headways benefits the users of the system. On the other hand, in scenarios with variable bus load, it is more beneficial for users to regularize the headways on the low-load stretches and allow the headways to deregulate on the high-load stretches.

The simulation scenario modeled with the traffic microsimulator software Aimsun Next, consisted of a circular BRT line proposed for the Metropolitan Region of Florianópolis with 31 km of length, 30 stations and 16 buses in operation. The tests were performed with patterns of concentrated and distributed demand.

The presented simulation results show that the proposed techniques resulted in a significant improvement in waiting time for onboard passengers, without penalizing the waiting time at the station for the concentrated demand pattern. It allows the conclusion that it is possible to reduce the waiting times of boarded passengers using a simple proportional feedback control

method only with a different distribution from the same amount of holding applied by existing methods.

The distributed demand shows that for the studied scenario, with less concentration of the load of onboard passengers, the behaviour of the proposed techniques approaches that of the fixed gain methods with fixed gain along the itinerary.

For future work, new forms of variation can be proposed for the gain of the proportional controllers considering other aspects, such as the predictive horizon of the predictive method. Historical data can provide the simplest methods with other indications for defining the best places to apply holding.

ACKNOWLEDGEMENTS

The authors acknowledge the support from CAPES and CNPq.

REFERENCES

- AIMSUN (2020) *Aimsun Next 8.4 Help Online*. Available at <<https://www.aimsun.com/>>. (Accessed in 11/05/2021).
- Barnett, A. (1974) On Controlling Randomness in Transit Operations. *Transportation Science*, v. 8, n. 2, p. 102-116. DOI: 10.1287/trsc.8.2.102.
- Cats, O.; A. Larijani; H. Koutsopoulos e W. Burghout (2011) Impacts of Holding Control Strategies on Transit Performance. *Transportation Research Record*, v. 2216, p. 51-58. DOI: 10.3141/2216-06.
- Ceder, A. (2007) *Public Transit Planning and Operation: Theory, Modeling and Practice*. Elsevier, Butterworth-Heinemann, Burlington, Massachusetts.
- Daganzo, C. F. (2010) *Public Transportation Systems: Basic Principles of System Design, Operations Planning and Real-Time Control*. ITS Berkeley, Berkeley, California. Available at <<https://escholarship.org/uc/item/46f4x3zf>>. (Accessed in 11/05/2020).
- Eberlein, X. J.; N. H. M. Wilson e D. Bernstein (2001) The Holding Problem with Real-time Information Available. *Transportation Science*, v. 35, n. 1, p. 1-18. DOI: 10.1287/trsc.35.1.1.10143.
- Ibarra-Rojas, O.; F. Delgado; R. Giesen e J. Muñoz (2015) Planning, Operation and Control of Bus Transport Systems: A Literature Review. *Transportation Research Part B: Methodological*, v. 77, p. 38-75. DOI: 10.1016/j.trb.2015.03.002.
- Koehler L.; W. Kraus e E. Camponogara (2011) Iterative Quadratic Optimization for the Bus Holding Control Problem. *IEEE Transactions on Intelligent Transportation Systems*, v. 12, n. 4, p. 1568-1575. DOI: 10.1109/TITS.2011.2164909.
- Lima, L. (2020) *Controle realimentado de intervalo entre ônibus com ganho variável de acordo com o carregamento*. Dissertação (mestrado). Programa de Pós-Graduação em Engenharia de Automação e Sistemas, Universidade Federal de Santa Catarina. Florianópolis. Available at <<https://repositorio.ufsc.br/handle/123456789/216157>>. (Accessed in 11/05/2020).
- Lima, L.; W. Kraus; R. Carlson e L. Zimmermann (2019) Controlador realimentado de intervalo entre ônibus com ganho variável de acordo com o carregamento. *33º Congresso da Associação Nacional de Pesquisa e Ensino em Transporte*.
- Newell, G. F. e R. B. Potts (1964) Maintaining a Bus Schedule. *2nd Australian Road Research Board Conference*. v. 2, n. 1, p. 388-393. Australian Road Research Board (ARRB), Melbourne.
- PLAMUS (2015) *Plano de Mobilidade Urbana Sustentável da Grande Florianópolis*. Available at <<http://observatoriodamobilidadeurbana.ufsc.br/>>. (Accessed in 11/05/2020).
- Turnquist, M. (1982) *Strategies for Improving Bus Transit Service Reliability*. Transportation Research Record 818. Evanston, IL: Northwestern University. Available at <<https://trid.trb.org/view/174188>>. (Accessed in 11/05/2020).
- Wright, L. e W. Hook (2007) *Bus Rapid Transit Planning Guide*. Institute for Transportation & Development Policy, New York. Available at <<https://www.itdp.org/2017/11/16/the-brt-planning-guide/>>. (Accessed in 11/05/2020).
- Zimmermann, L. (2016) *Controle de Intervalos entre Ônibus: Comparação entre Métodos Realimentados Clássicos e Controle Preditivo Baseado em Modelo*. Dissertação (mestrado). Programa de Pós-Graduação em Engenharia de Automação e Sistemas, Universidade Federal de Santa Catarina. Florianópolis. Available at <<https://repositorio.ufsc.br/handle/123456789/175840>>. (Accessed in 11/05/2020).
- Zimmermann, L.; W. Kraus e L. A. Koehler (2015) Análise de Estratégias Realimentadas para Controle por Retenção do Intervalo Entre Ônibus. *29º Congresso da Associação Nacional de Pesquisa e Ensino em Transporte*.
- Zimmermann, L.; W. Kraus; L. A. Koehler e E. Camponogara (2016) Holding Control of Bus Bunching without Explicit Service Headways. *IFAC-PapersOnLine*, v. 49, n. 3, p. 209-214. DOI: 10.1016/j.ifacol.2016.07.035.